

ISO 9001:2000
CERTIFIED

LEAD FREE AVAILABLE



Ball Grid Array Sockets & Adapters

only from **Andon**
New **Rollerball**® Sockets
with Solderballs

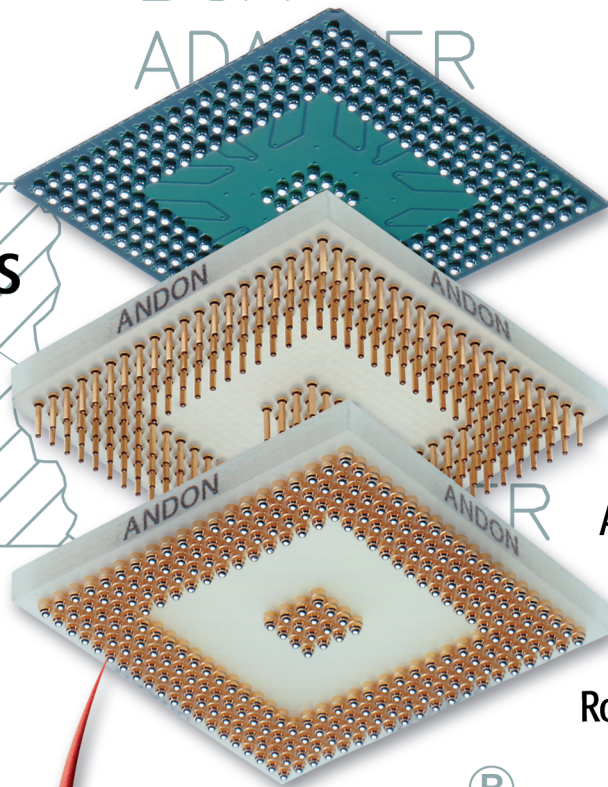

BGA
Device

BGA
Adapter

Rollerball®
Socket

ROLLERBALL®
SOCKET

Solder
Rollerball®
Patented

PCB

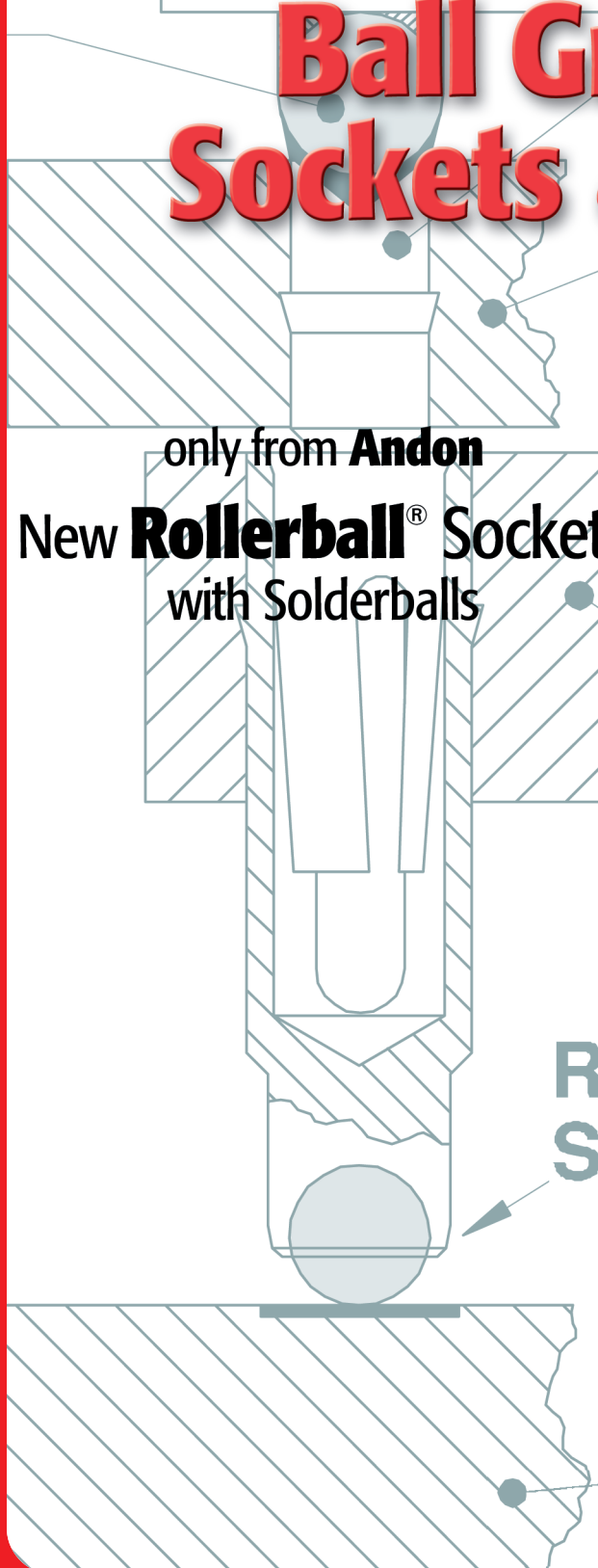

ANDON HAS BECOME recognized as the Inter-connection Specialist, offering a single, reliable source for IC sockets, micro-precision sockets, adapters, board-to-board interconnects and contact/terminal products. Over the years Andon has set the industry standard for innovation, reliability and superior quality.

Andon's ISO 9001 certified facility offers leading edge tooling, high-temperature molding, stamping, screw machine products and automated assembly capabilities. The result is a line of products, like our Rollerball™ Socket technology, that brings true problem solving product process innovation and cost savings to the industry.

Whether you need large or small volume production, stock solutions or custom sockets and interconnects, Andon has the inherently smart, simple and cost-effective solutions to make you more productive.



Andon President, John O. Tate, pioneered many of the innovative, high-reliability interconnects for military, aerospace and commercial applications that have become industry standards. In 1965, he developed the stamped and formed multi-finger precision IC socket contact, which remains the preferred method throughout the world for connecting today's microprocessors and other critical components.

- **ANDON** produces a large variety of board level interconnects
- **ANDON** has over 40 years experience in high-rel socket and connector manufacture
- **ANDON** specializes in high-precision turned parts (screw machine) to close tolerance and down to micro-miniature sizes
- **ANDON** provides high-rel solutions to interconnect problems with the proven “2-piece stamped and formed contact/terminal (screw machine)” design which prevents solder wicking onto the contact
- **ANDON** provides design and engineering services for custom interconnects
- **ANDON** provides prototypes up to large volume automated production
- **ANDON** provides conversion sockets for straight pin components converted to SMD sockets
- **ANDON** is your

“Reliable Partner For Progress”

Cutaway View of Andon's High-Rel Socket

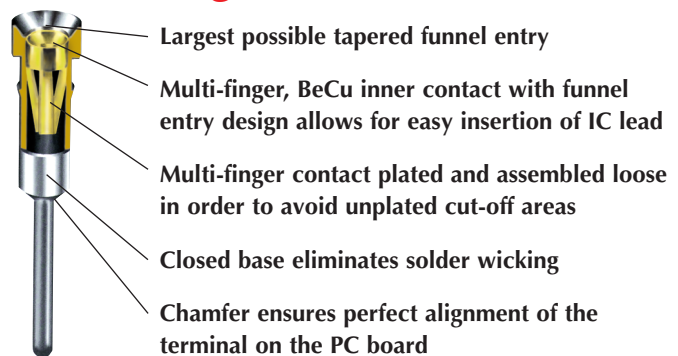

BGA Rollerball™ Sockets*

Designed to revolutionize BGA assembly and improve reliability and quality!

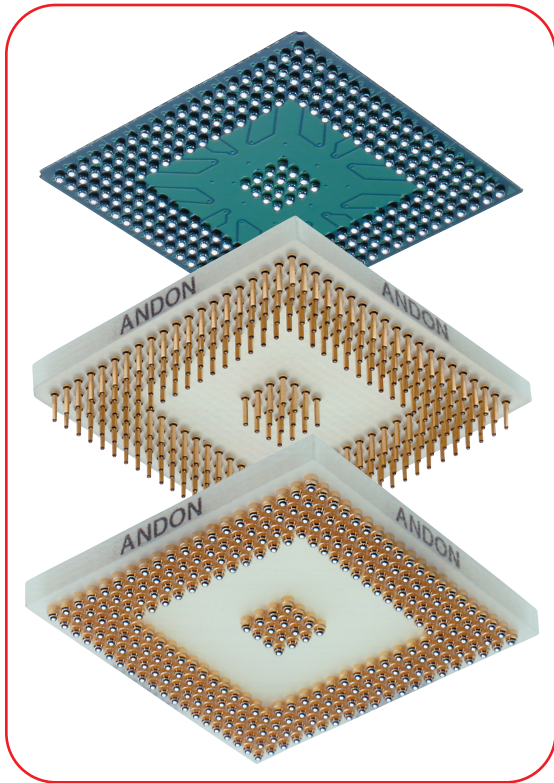

- Innovative solution for PCB coplanarity assembly problems
- The only socket design that provides the highest thru-put and quality
- Solder sphere is mechanically assembled into the terminal and positioned closer to the PCB for extremely accurate soldering every time

Rollerball™ Sockets eliminate many problems inherent in the shipping and assembly of conventional BGA sockets. The unique design also improves performance characteristics and reduces expensive rework and scrap while increasing production yields. The key to Andon's new design is a radiused hole at the bottom of the terminal. The terminal is then crimped over the solder ball beyond its hemisphere to encapsulate the solder ball, leaving just enough of the solder ball exposed to provide sufficient solder for soldering to a PCB. Some ASICs with large ball counts using the conventional BGA terminal design experience

coplanarity tolerance

problems when there is no metal-to-metal contact between the solder ball and the PCB pad. The solder ball will tend to flow toward the gold plated land area under the microprocessor or socket terminal and not downward to make contact with the PCB pad. With Andon's Rollerball™ Socket design, the critical distance between the terminal and the PCB pad is typically reduced from .036"-.040" to .018"-.022". The solder becomes part of the "anchor" cross section and provides additional mechanical strength to the connection as well as improved electrical connectivity.

Because it also provides controlled dispersion of solder, the encapsulated solder ball in the new Rollerball™ Socket also reduces the risk of solder bridging inherent in conventional solder ball terminal designs.

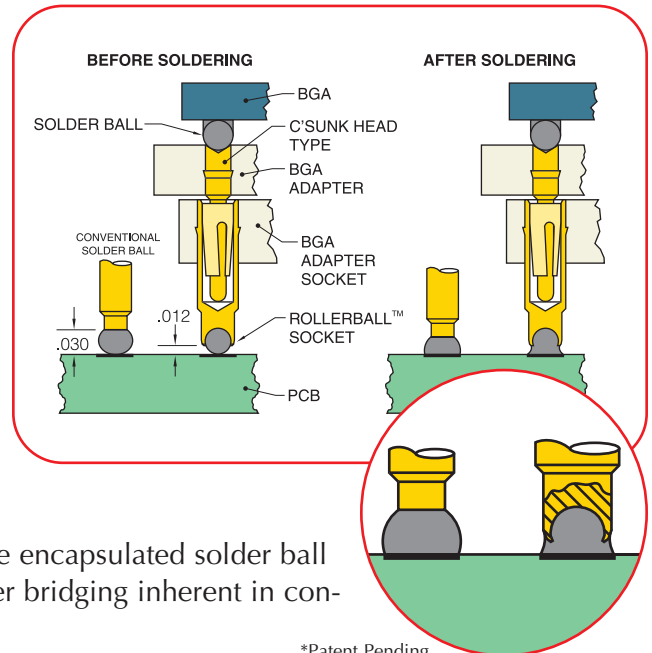

*Patent Pending

ANDON ELECTRONICS CORPORATION
4 Court Drive Lincoln, RI 02865 USA

Tel: 401-333-0388 Fax: 401-333-0287
E-mail: info@andonelect.com
Web Site: www.andonelect.com

1.27 mm (.050 inch) Pitch BGA Sockets and Adapters Ball Grid Array Socketing System

The Ideal Solution To Fix BGA Assembly Problems On Large PCBs

- ADAPTER WITH TERMINAL PINS FOR PLUGGING INTO SOCKET. BGA SOLDERED DIRECTLY ONTO ADAPTER.
- SOCKET WITH TERMINALS FOR SOLDERING DIRECTLY ONTO PCB WITH PLATED THRU HOLES OR SURFACE MOUNT PADS.
- REWORK COST AND RISK OF DAMAGE REDUCED TO EXPENSIVE BGA AND MULTI LAYER PCB'S.

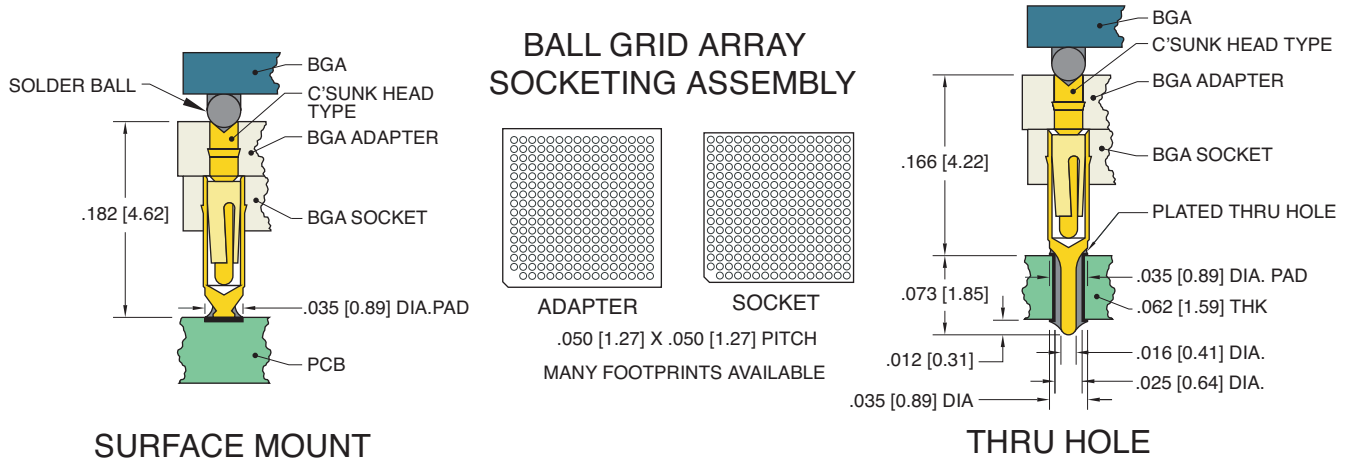

Terminal Types

ADAPTER TERMINALS

SOCKET TERMINALS

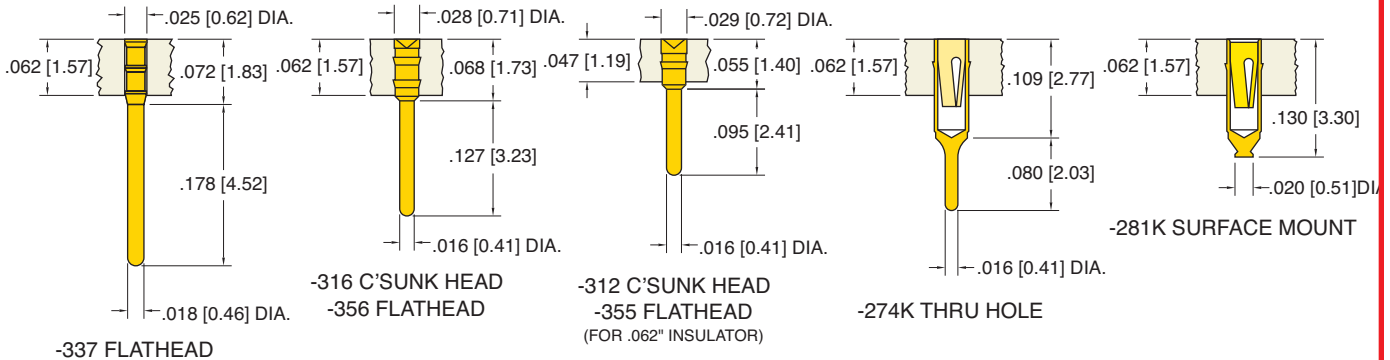

TECHNICAL SPECIFICATIONS

Material: FR-4 Laminate U.L. Rated 94V-0
 Insulator: Brass Plated Gold
 Terminal: BeCu Plated Gold
 Contact: Brass Plated Gold
 Adapter: Brass Plated Gold

ORDERING INFORMATION

10-XX-XX-XXX-XXX-XXX-N10

Series — Plating
 Grid — Terminal Type
 Footprint — Number of Pins

© ANDON 2001. DIMENSIONS ARE SHOWN IN INCHES [MILLIMETERS]. WE RESERVE THE RIGHT TO CHANGE SPECIFICATIONS WITHOUT NOTICE. DSBGA-1

1.27 mm (.050 inch) Pitch BGA Sockets and Adapters Rollerball™ Grid Array Socketing System

The Ideal Solution To Fix BGA Assembly Problems On Large PCBs

- **ADAPTER** WITH TERMINAL PINS FOR PLUGGING INTO ROLLERBALL™ SOCKET. BGA SOLDERED DIRECTLY ONTO ADAPTER.
- **SOCKET** WITH ROLLERBALL™ TERMINALS FOR SOLDERING DIRECTLY ONTO PCB.
- **REWORK** COST AND RISK OF DAMAGE REDUCED TO EXPENSIVE BGA AND MULTI LAYER PCB'S.

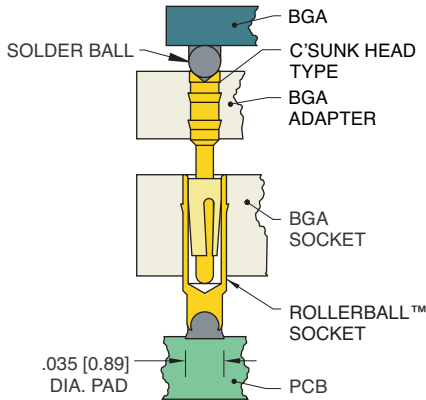

SURFACE MOUNT

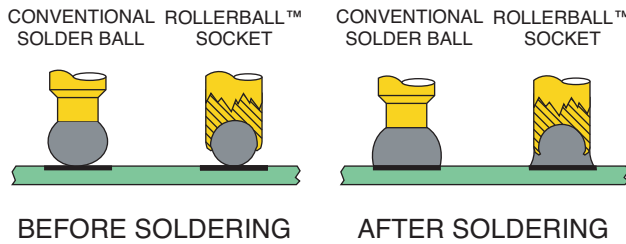

ROLLERBALL™ GRID ARRAY SOCKETING ASSEMBLY
Patent Pending

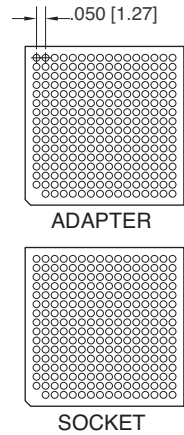

.050 [1.27] X .050 [1.27] PITCH
MANY FOOTPRINTS AVAILABLE

Terminal Types

ADAPTER TERMINALS

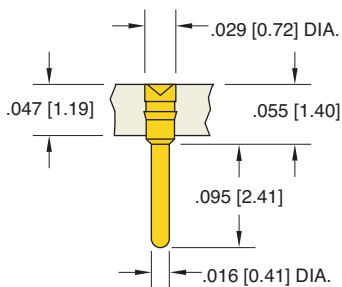

-312 C'SUNK HEAD
-355 FLATHEAD
(FOR .062" INSULATOR)

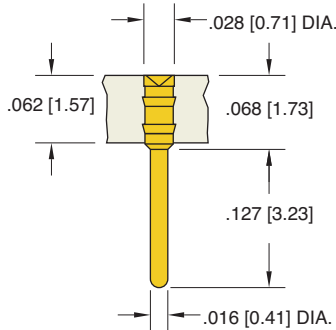

-316 C'SUNK HEAD
-356 FLATHEAD

SOCKET TERMINAL

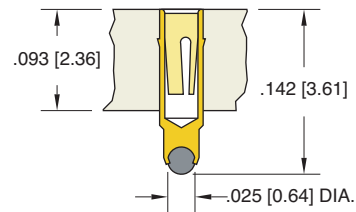

-RB338K ROLLERBALL™ SOCKET

TECHNICAL SPECIFICATIONS

Material:	
Insulator:	FR-4 Laminate U.L. Rated 94V-0
Terminal:	Brass Plated Gold
Contact:	BeCu Plated Gold
Solderball:	63% Tin, 37% Lead
Adapter:	Brass Plated Gold

ORDERING INFORMATION

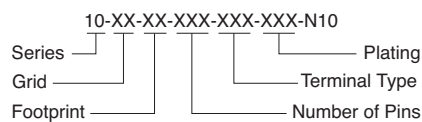

© ANDON 2001. DIMENSIONS ARE SHOWN IN INCHES [MILLIMETERS]. WE RESERVE THE RIGHT TO CHANGE SPECIFICATIONS WITHOUT NOTICE. DSBGA-2

1 mm (.0394 inch) Pitch BGA Sockets and Adapters Ball Grid Array Socketing System

The Ideal Solution To Fix BGA Assembly Problems On Large PCBs

- ADAPTER WITH TERMINAL PINS FOR PLUGGING INTO SOCKET. BGA SOLDERED DIRECTLY ONTO ADAPTER.
- SOCKET WITH TERMINALS FOR SOLDERING DIRECTLY ONTO PCB WITH PLATED THRU HOLES OR SURFACE MOUNT PADS.
- REWORK COST AND RISK OF DAMAGE REDUCED TO EXPENSIVE BGA AND MULTI LAYER PCB'S.

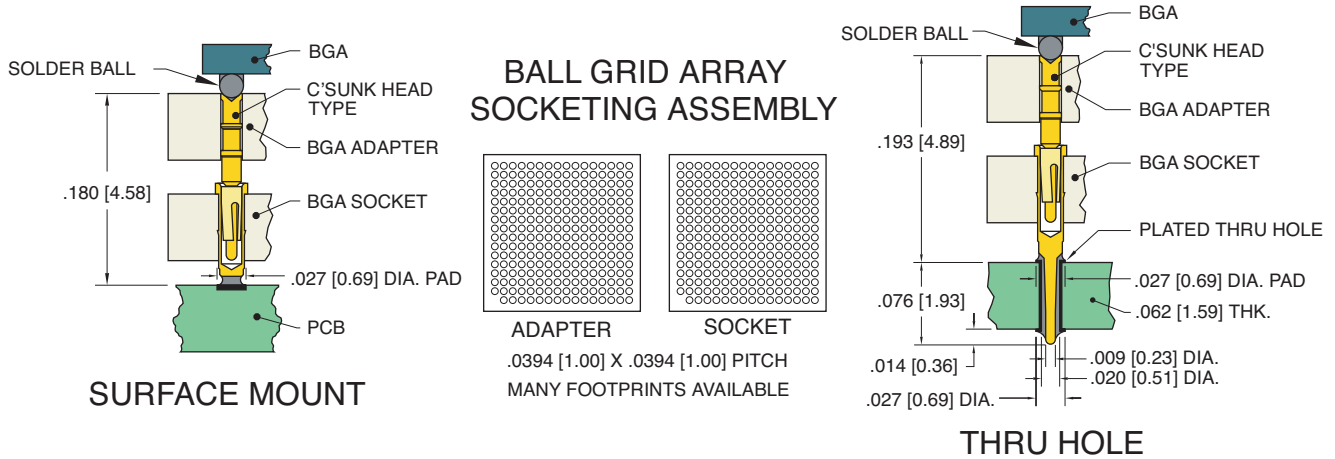

Terminal Types

ADAPTER TERMINAL

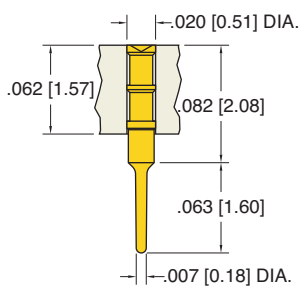

-320 C'SUNK HEAD
-321 FLATHEAD

SOCKET TERMINALS

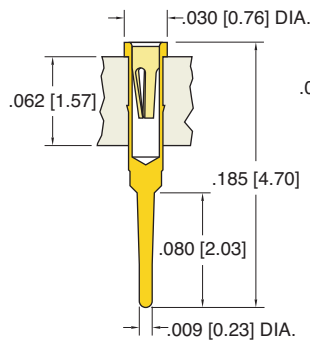

-347T THRU HOLE

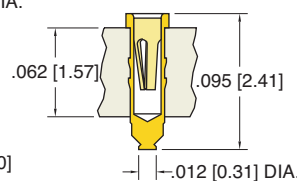

-319T SURFACE MOUNT

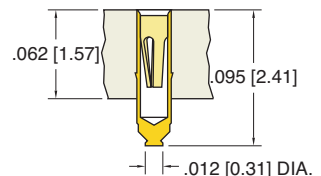

-329T SURFACE MOUNT

TECHNICAL SPECIFICATIONS

Material:
Insulator: FR-4 Laminate U.L. Rated 94V-0
Terminal: Brass Plated Gold
Contact: BeCu Plated Gold
Adapter: Copper Alloy Plated Gold

ORDERING INFORMATION

12-XX-XX-XXX-XXX-XXX-N10

Series ———— Plating
Grid ———— Terminal Type
Footprint ———— Number of Pins

© ANDON 2001. DIMENSIONS ARE SHOWN IN INCHES [MILLIMETERS]. WE RESERVE THE RIGHT TO CHANGE SPECIFICATIONS WITHOUT NOTICE. DSBGA-3

1 mm (.0394 inch) Pitch BGA Sockets and Adapters Rollerball™ Grid Array Socketing System

The Ideal Solution To Fix BGA Assembly Problems On Large PCBs

- ADAPTER WITH TERMINAL PINS FOR PLUGGING INTO ROLLERBALL™ SOCKET. BGA SOLDERED DIRECTLY ONTO ADAPTER.
- SOCKET WITH ROLLERBALL™ TERMINALS FOR SOLDERING DIRECTLY ONTO PCB.
- REWORK COST AND RISK OF DAMAGE REDUCED TO EXPENSIVE BGA AND MULTI LAYER PCB'S.

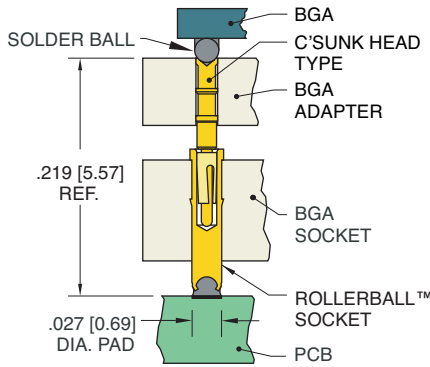

SURFACE MOUNT

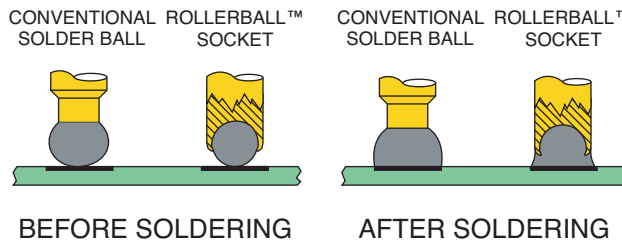

ROLLERBALL™ GRID ARRAY SOCKETING ASSEMBLY

Patent Pending

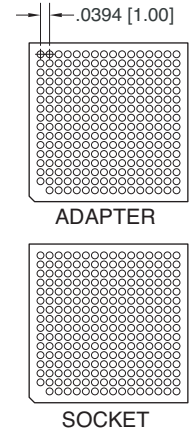

.0394 [1.00] X .0394 [1.00] PITCH
MANY FOOTPRINTS AVAILABLE

Terminal Types

ADAPTER TERMINAL

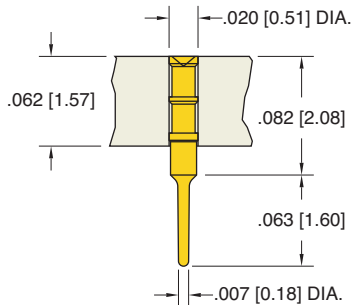

-320 C'SUNK HEAD
-321 FLATHEAD

SOCKET TERMINAL

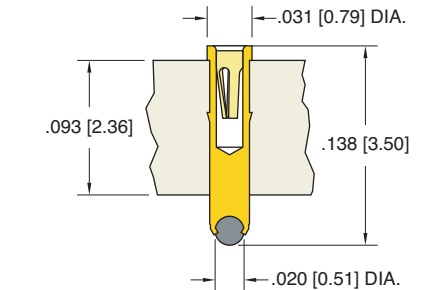

-RB339T SURFACE MOUNT ROLLERBALL™

TECHNICAL SPECIFICATIONS

Material:
Insulator: FR-4 Laminate U.L. Rated 94V-0
Terminal: Brass Plated Gold
Contact: BeCu Plated Gold
Solderball: 63% Tin, 37% Lead
Adapter: Copper Alloy Plated Gold

ORDERING INFORMATION

12-XX-XX-XXX-XXX-XXX-N10
Series | Grid | Footprint | Plating | Terminal Type | Number of Pins

Socket Assemblies For Multi-Pin Connectors

1.27 mm (.050 inch) Pitch

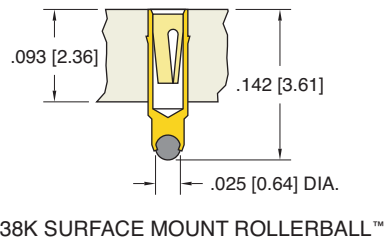
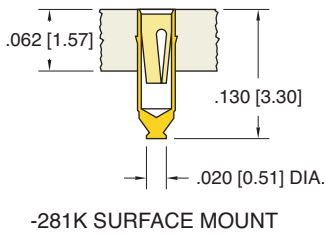
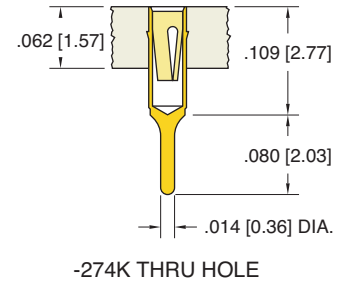
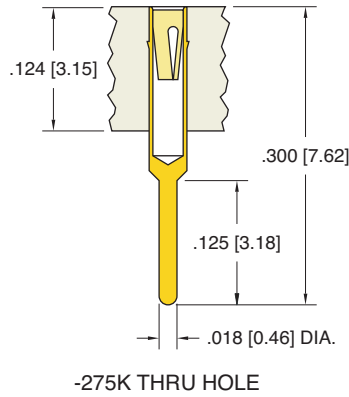
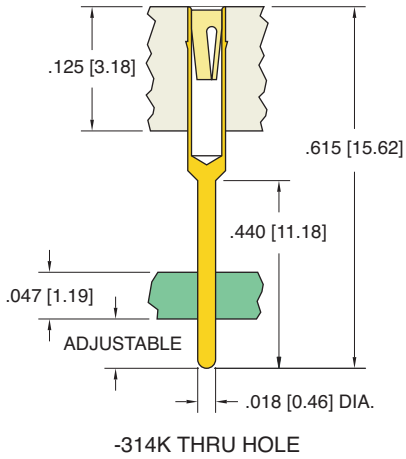

1 mm (.0394 inch) Pitch

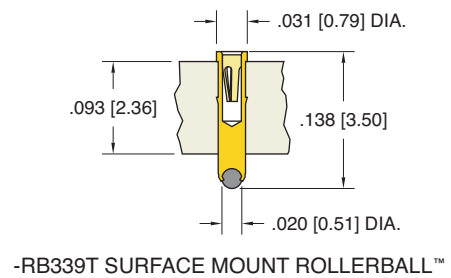
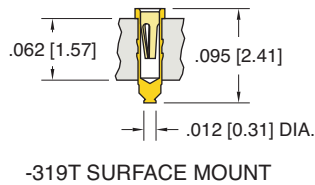
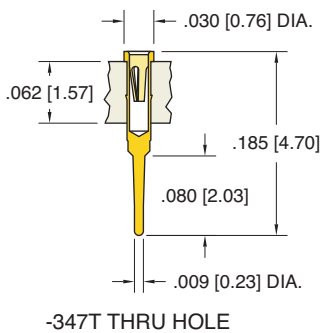

© ANDON 2001. DIMENSIONS ARE SHOWN IN INCHES [MILLIMETERS]. WE RESERVE THE RIGHT TO CHANGE SPECIFICATIONS WITHOUT NOTICE. DSBGA-5

Adapter Terminals For Multi-Pin Connectors

1.27 mm (.050 inch) Pitch

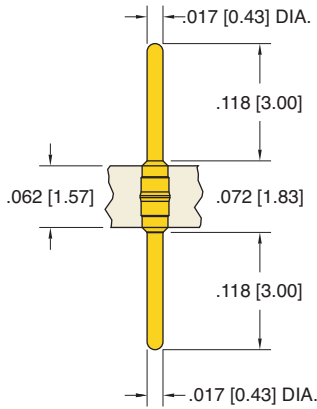

-308 BOARD TO BOARD

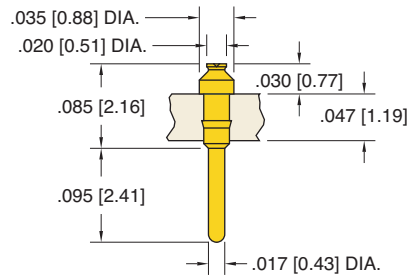

-288 DAUGHTER BOARD

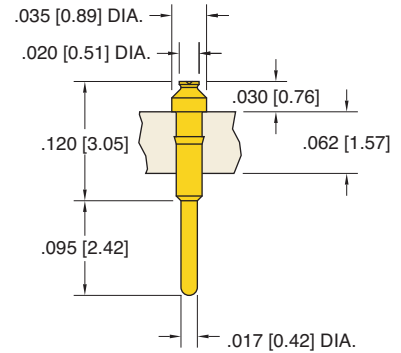

-323 DAUGHTER BOARD

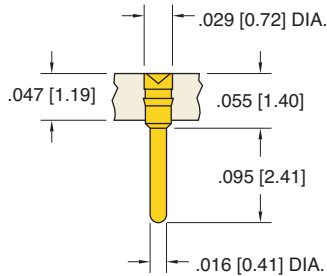

-312 C'SUNK HEAD BGA
-355 FLATHEAD BGA

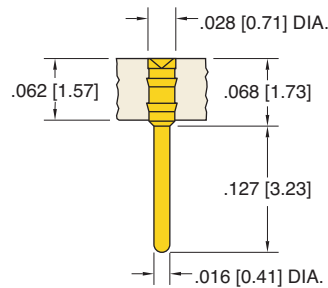

-316 C'SUNK HEAD BGA
-356 FLATHEAD BGA

1 mm (.0394 inch) Pitch

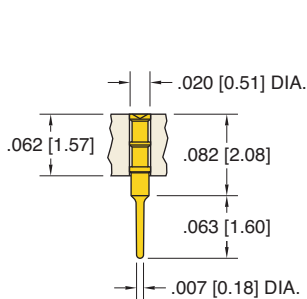

-320 C'SUNK HEAD BGA
-321 FLATHEAD BGA

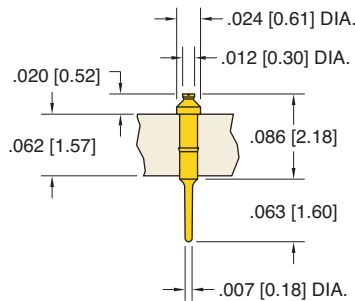

-330 DAUGHTER BOARD

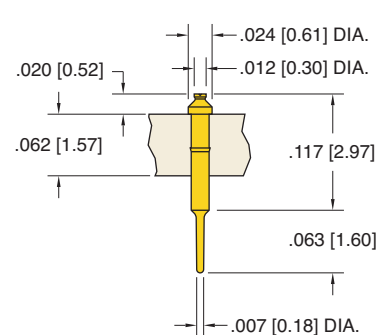

-332 DAUGHTER BOARD

© ANDON 2001. DIMENSIONS ARE SHOWN IN INCHES [MILLIMETERS]. WE RESERVE THE RIGHT TO CHANGE SPECIFICATIONS WITHOUT NOTICE. DSBGA-6

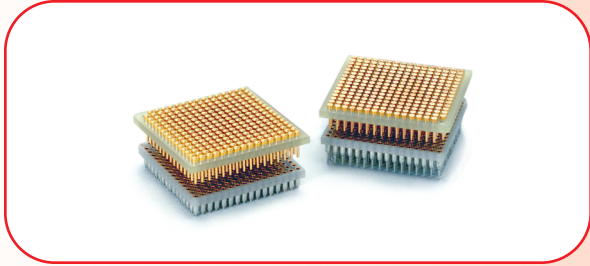

BGA Sockets and Adapters

Provide an ideal method for mounting ball grid array devices onto a PCB. The device is soldered to the adapter, simplifying solder verification and testing. The device/adapter assembly then plugs into the BGA socket which is permanently soldered to the PCB. The BGA adapter is offered with either flat or countersunk heads. Our BGA sockets can be surface or thru-hole mounted. Socket insulators are made of FR-4 to withstand convection soldering. Andon BGA sockets and adapters are available in virtually any size or configuration, using off-the-shelf or custom designed screw machine terminals.

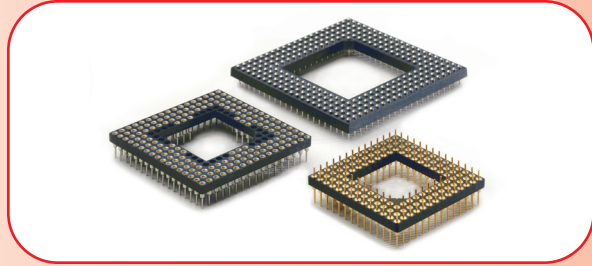

PGA Sockets and Adapters

Andon pin grid array sockets and PGA adapters are perfect for high pin count microprocessors. Andon offers the widest selection of standard footprints, from 5x5 to 26x26, as well as custom designed PGA sockets. Andon PGA sockets offer a choice of insertion and extraction forces, including Andon's exclusive 1 oz. ultra low-force contact. Standard insulators are made of high-temperature Nylon 46, suitable for IR, convection and wave soldering. Custom PGA sockets are available with insulators made of thick glass epoxy FR-4 or polyimide. Many terminals and pin lengths are available.

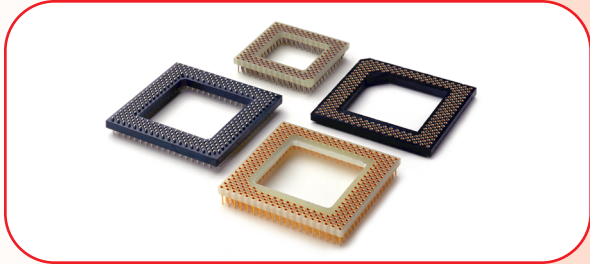

IPGA Sockets and Interconnects

Connect high pin count ICs with interstitial footprints with Andon IPGA sockets and interconnects. Socket insulators are made of FR-4 or molded plastic UL94V-0 to withstand wave or convection soldering. Precision machined pins offer the lowest possible profile. The closed bottom design eliminates flux and solder contamination. Our exclusive one-ounce socket contact design, produced in-house, reduces damage to both the device and the substrate.

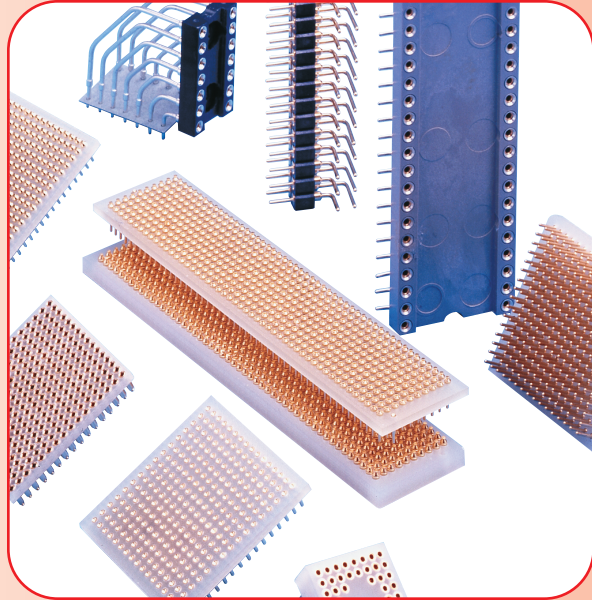

Right angle sockets and adapters, multi-pin connectors, LED sockets and many other products are available from Andon.

ANDON ELECTRONICS CORPORATION
4 Court Drive Lincoln, RI 02865 USA

Tel: 401-333-0388 Fax: 401-333-0287
E-mail: info@andonelect.com
Web Site: www.andonelect.com

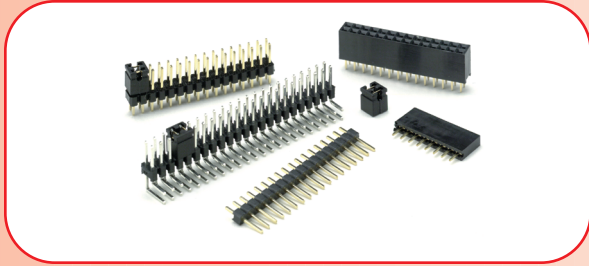

Jumpers, Pin Headers and Receptacles

Andon pin headers and receptacle headers provide ideal board-to-board interconnections. Andon pin headers are X/Y stackable, and are available in 2.54 mm, 2 mm and the exclusive 1 mm pitch, with single or dual row, straight or right angle terminals. Standard lengths are up to 50 pin positions (50 x 10 pin positions for 500 pin). Other miniature sizes are available upon request. We offer mini shorting jumpers in 2.54 mm, 2 mm and new 1 mm pitch, as well as a multi-jumper. There's also a family of 2.54 mm pitch receptacle headers, including both single and dual row versions, with either straight or right angle terminals.

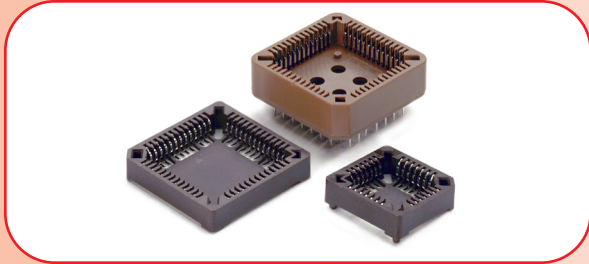

PLCC and LCC Sockets

Andon offers a wide variety of thru-hole and SMD PLCC and LCC sockets to accept JEDEC type substrates. For High-Rel, high shock and high vibration applications, we offer edge wipe contacts made of flat heavy gauge copper alloy. For low cost applications, Andon utilizes face wipe contacts made of rolled-leaf copper alloy. All sockets use UL94V-O insulators. Sockets are available in tubes, trays or tape and reel.

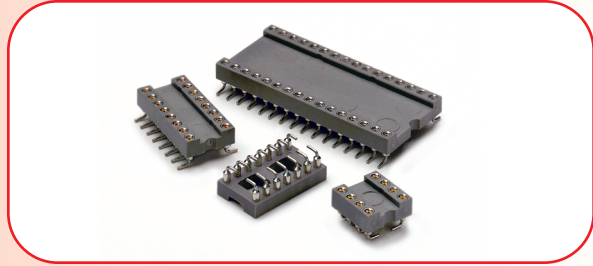

SMD Gull Wing and "J" Lead DIP Sockets

Andon surface mount gull wing and "J" lead DIP sockets are ideally suited for "pick and place." Our gull wing sockets provide maximum strength solder joints as well as easy in-circuit testing. Andon gull wing DIP sockets are available in a wide variety of configurations, including open and solid frame varieties. Andon "J" lead DIP sockets are specially designed for soldering to existing footprints. Both gull wing and "J" lead DIP sockets are available with insulators made of molded plastic UL94V-O or blue FR-4 epoxy, suitable for IR or convection soldering. All sockets feature High-Rel 4-finger socket contacts.

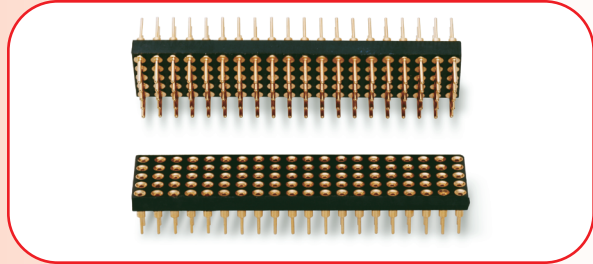

Board-to-Board Connectors

Stacking boards to any height spacing is made easy with Andon's large choice of terminal lengths, sockets and connectors to mix or match to obtain the required board-to-board spacing. Rugged and reliable, Andon offers a variety of multi-finger contacts to provide the right insertion and withdrawal forces.

ANDON ELECTRONICS CORPORATION
4 Court Drive Lincoln, RI 02865 USA

Tel: 401-333-0388 Fax: 401-333-0287
E-mail: info@andonelect.com
Web Site: www.andonelect.com

Send For Our Full Line Catalog



Represented by:

Distributed by:



ANDON ELECTRONICS CORPORATION
4 Court Drive Lincoln, RI 02865 USA

Tel: 401-333-0388 Fax: 401-333-0287
E-mail: info@andonelect.com
Web Site: www.andonelect.com